

MatchSticks: Woodworking through Improvisational Digital Fabrication

Rundong Tian, Sarah Stermann, Ethan Chiou, Jeremy Warner, Eric Paulos
Electrical Engineering and Computer Sciences, University of California, Berkeley
{rutian, ssterman, ethanchiou, jeremy.warner, paulos}@berkeley.edu



Figure 1. MatchSticks is a new digital fabrication system for woodworking (A). Wooden objects larger than the size of the machine can be easily made using a parametric joint library (B and C). We evaluate our system with users (D) who followed an on-screen tutorial to create a parametric box.

ABSTRACT

Digital fabrication tools have broadened participation in making and enabled new methods of rapid physical prototyping across diverse materials. We present a novel smart tool designed to complement one of the first materials employed by humans — wood — and celebrate the fabrication practice of joinery. Our tool, MatchSticks, is a digital fabrication system tailored for joinery. Combining a portable CNC machine, touchscreen user interface, and parametric joint library, MatchSticks enables makers of varying skill to rapidly explore and create artifacts from wood. Our system embodies tacit woodworking knowledge and distills the distributed workflow of CNC tools into a hand tool; it operates on materials existing machines find difficult, produces assemblies much larger than its workspace, and supports the parallel creation of geometries. We describe the workflow and technical details of our system, present example artifacts produced by our tool, and report results from our user study.

ACM Classification Keywords

H.5.2 User Interfaces: Prototyping

Author Keywords

Fabrication; Prototyping; Woodworking

INTRODUCTION

Digital fabrication with wood currently centers around using CNC routers to cut shapes out of planar materials such as

plywood. While this technique is capable of producing highly complex geometries, it does not appropriately address the geometries required by many woodworking tasks.

Current Practice: Consider the chair in Figure 2 created using a traditional CNC router. To produce this chair from plywood, one must have access to a CNC router as big as the largest piece in the design (in this example, the size of the c-shaped leg sub-assemblies) or access to a much smaller position correcting router as presented in [14]. However, many of the cuts present in the design are straight lines that would be produced much more efficiently with other tools. The precision of the CNC router is only truly needed at the detailed joinery sites where pieces physically connect.

While the constitutive components of the final model appear more like lumber, these geometries are created in a roundabout way by cutting down large, rectangular panels of plywood. Though this process appears inefficient, lumber (which can have slim aspect ratios resembling 1-D stock material) can be difficult to work with using CNC tools, which are optimized for planar stock material. Recognizing this opportunity, and combined with our interest in hybrid approaches to making, we have created MatchSticks, a tool specifically for creating joints in lumber.

Creating furniture and the associated joinery is a hands-on and personal process that is a rich domain for the exploration of craft practices. Rather than focus on software that can create fully defined 3D models to be delegated to an omnipotent digital fabrication tool, we explore how a system of parametric joinery and a context specific CNC tool can give rise to interactions and affordances more similar to hand tools, augmenting the users' abilities while maintaining their autonomy.

Permission to make digital or hard copies of part or all of this work for personal or classroom use is granted without fee provided that copies are not made or distributed for profit or commercial advantage and that copies bear this notice and the full citation on the first page. Copyrights for third-party components of this work must be honored. For all other uses, contact the Owner/Author.
CHI 2018, April 21–26, 2018, Montréal, QC, Canada.
©2018 Copyright is held by the owner/author(s).
ACM ISBN 978-1-4503-5620-6/18/04.
<https://doi.org/10.1145/3173574.3173723>



Figure 2. A chair design hosted by Opendesk.cc. Though the visual form suggests that the structure of the chair is created from lumber, it is in fact milled out of a large sheet of plywood.

Existing Fabrication Metaphors

Many digital fabrication tools lend themselves to prescribed methods of interaction. For example, the following properties are found in most traditional digital fabrication systems:

Siloed — The making process is broken into three distinct phases: users (1) design digital models using software, (2) convert that model to a machine parsable form (e.g. ‘slicing’, CAM programming, etc.), and (3) wait for the machine to produce the final object.

Geometry Agnostic — Digital fabrication tools provide equal form-giving consideration and focus across the entire work area without regard to the underlying intent of the design (e.g. sites of precise joinery vs. sites of straight line cuts).

Serial — A single machine is dedicated to operate across the entire stock material, neglecting opportunities for parallelism.

Limited Build Volume — Most digital fabrication tools can only make objects at the scale of the machine workspace.

MatchSticks Fabrication Metaphors

We adapt the traditional metaphors outlined in the previous subsection to enable a creative making process that is:

Interactive — We develop a more fluid and hybrid making [28] process that positions the tool and user as collaborators. Our design avoids the design-convert-wait workflow by positioning itself as a flexible smart workshop tool that is fully self-contained and can be independent of any external CAD or CAM software.

Geometry Conscious — For many structures (e.g. tables, benches, shelves, dwellings, etc.) the sites of highest fabrication complexity are at the joints. For our system, the capabilities of a CNC machine are invested exclusively into fabricating geometries that most require the accuracy and repeatability of Computer Numeric Control.

Parallel — We explore how a smaller set of specialized tools can be used more efficiently to outperform a single complex general purpose tool. Specifically, how a collection of networked, interactive, low cost, joinery specific smart-tools can be used in parallel to provide rapid fabrication capabilities and lead to new modes of human-machine making interactions.

Beyond Machine Scale — We leverage the localized nature of joinery to create tools that lend themselves towards making objects much larger than the tooling and workspace. Tools of this

nature have the potential to enable individuals to rethink digital fabrication, expanding design and fabrication workflows beyond the workspace constraints embedded within current digital fabrication practice.

Envisioned Practice: As an example, consider a user designing and fabricating a similar chair to Figure 2, using a system that leverages these new fabrication metaphors.

Rather than designing an entire detailed 3D model of the chair on the computer, she sits down in the workshop with her materials and sketches a few ideas that capture the overall size and topology of the chair. Instead of delegating the entire fabrication process to the machine, she works interactively with the system and her materials to determine what joints would be best suited for the design.

She uses other woodworking tools such as table saws and miter saws in tandem, each used for the geometries that they are best suited to create. When she is ready to make a joint, the system guides her on how to fixture the pieces such that both sides of the joint will mate properly after they are cut.

When a mistake is made, she recovers gracefully, either re-cutting a single joint, or modifying the geometries of the chair to accommodate the happy little accident¹. The mistake is known immediately after it is made, as components are iteratively created and assembled.

Because this system is much smaller and cheaper than other CNCs, the makerspace she is working in has many of these joinery machines. She is able to use more than one in parallel to create this chair. When a friend offers to help on her project, they work on the chair together.

MatchSticks

We operationalize this philosophy in a new machine tool for joinery. Specifically, our tool comprises:

1. A novel machine tool capable of easily fixturing wood in various orientations to enable cuts on the edge and ends. Many of these geometries are substantially more difficult to create using existing tools due to undercuts and other geometric constraints (Figures 3, 4).
2. A touch screen display mounted on the machine as the primary interface for interacting with the tool (Figure 3).
3. A parametric joint library that can be scaled to lumber of various sizes. These files are stored as SVGs to allow the underlying representation of joints to be easily extendable by end users (Figure 8).
4. A toolpath generator to create machining toolpaths based on the SVG representation of joints.
5. A web application which handles the data storage, toolpath calculation and user interface, and allows the MatchSticks software to be agnostic to the underlying hardware.

JOINERY

While it is possible to carve a bookshelf directly from a log, objects are often constructed from wood that has been sawn into boards to maximize material usage. As such, knowledge of

¹https://en.wikipedia.org/wiki/Bob_Ross

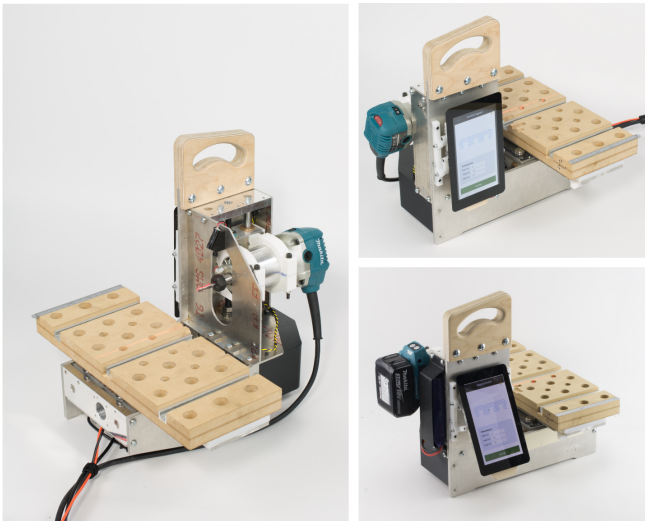

Figure 3. Our tool consists of a 3-axis CNC machine, trim router, touch screen for user interaction, line laser for quickly and accurately aligning cuts, and a modular build bed that accepts a variety of fixtures and alignment pins. During wireless operation, the motors run from a LiPo battery and a battery powered trim router is used.

how to join these lumber boards is essential to woodworking. Creating joinery requires both theoretical knowledge of the capabilities and aesthetics of joinery, as well as the tacit knowledge required in its construction. Many types of joinery exist, ranging from intricate double-blind dovetails to nailing boards together with a hammer. In this project, we turn our attention to joints that are stable with no additional hardware, which are valued for their strength and aesthetic beauty. Example joints created by our system can be seen in Figure 8.

Many tools can be used to create joinery. Manual tools such as saws and chisels can be used to create nearly all joinery; their capabilities are limited only by the artisan's skill.

Power tools are also used to create joinery. In addition to table saws, miter saws, and drill presses, many specialized jigs and tools exist. These joinery tools are often single purpose. To give a few examples, hollow chisel mortisers drill square holes, biscuit joiners cut shallow grooves used to align and reinforce simple joints, doweling jigs are used with a hand drill to make evenly spaced holes, and the Festool Domino² cuts slots for tenons. One of the most versatile power tools used to create joinery is a router: a rotary tool that removes material using spinning bits. In combination with templates, a router can produce joinery such as finger joints and dovetail joints.

Routers have also been integrated in flatbed CNC machines for woodworking use. However, these tools often have a strong preference for planar stock materials and one preferred orientation for fixturing. These constraints limit the geometry, aesthetics, and strength of joinery that can be fabricated.

In contrast, our tool is a CNC machine tailored for joinery. Compared to other methods for creating joinery, our tool (1) does not require a high level of manual skill to use; (2) does not require a large collection of power tools and templates for

²<https://www.festoolusa.com/products/domino-joining-system>

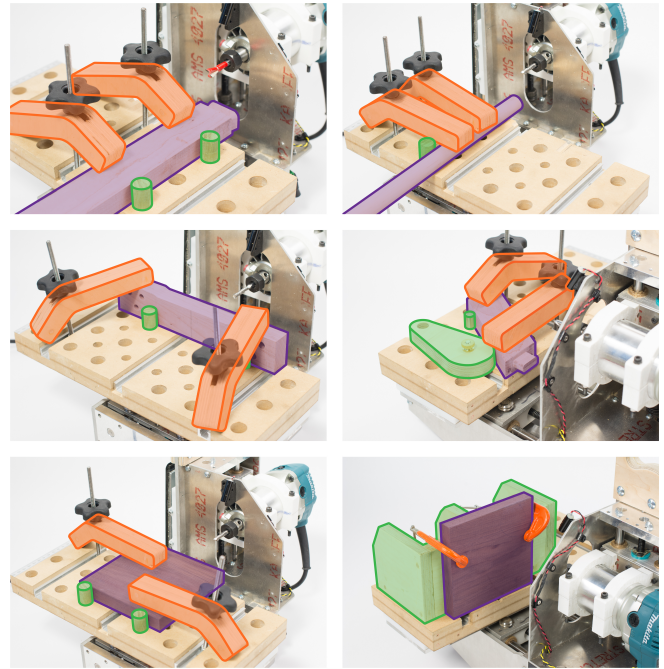

Figure 4. One strength of our machine tool is its ability to rapidly fixture components in a variety of orientations. This allows us to create geometries that would be substantially more difficult to create because of physical constraints such as undercuts. Left to right from top left: using our system, machining can occur at the ends of lumber, on round stock material, across edge profiles, at angles, in-line with the edge of a board, and on the surface of boards. This is made possible by modular components for fixturing (orange) and alignment (green). Workpiece shown in purple.

creating each type of joint, as joints are encoded in software, and output via a CNC stage; and (3) does not involve a large CNC machine that is ill-matched for joinery in lumber because of its size and preference for large 2D stock material.

RELATED WORK

Designing Beyond CAD

Despite the growing ubiquity of digital fabrication tools, modeling the complex parts and assemblies they can produce is outside the reach of many novice makers. To lower this threshold, HCI practitioners have investigated how designs for digital fabrication can be created in other ways. Interactive mechatronic devices can be more easily designed through sculpting with clay, using paper and physical proxies to annotate components (such as joysticks, potentiometers, etc.) [17, 5]. Mixed reality interfaces incorporate existing objects into a model suitable for digital fabrication [22]. These projects focus on the difficulty of interfacing parts to one another; similarly, we address the challenges of joining wood.

Designing and Creating Assemblies

Joining two components together is often a non-trivial task, in both the design and fabrication stages of a project. Much work has gone into addressing this fundamental challenge in the context of furniture. Such efforts include deducing fabricable 3D models from 'looks like' 3D models [10], automatic generation of interlocking furniture designs [3], and interactive

design of aesthetic joints [24]. More generally, joining two objects together using computationally generated 3D printed connectors was explored in [9].

Smart Tools and Hybrid Making

A manual tool such as a chisel can be utilized with extreme accuracy and finesse by an adroit artisan, but the capabilities of the chisel are in its symbiosis with the user, not inherent to the tool. Manual tools can be made ‘smart’ [27] by incorporating sensors and actuators that complement the tacit skill of a user, or embody the tacit knowledge of a skilled craftsman.

Many of these new smart tools involve tracking the position of the tool. In 3D, carving with a high speed rotary tool was augmented by tracking with a 6DOF Fastrak sensor [28]. In 2D, visual markers allowed tracking to compensate for the coarse movements of the user with a small CNC stage [14]. Carpentry tools such as drills and miter saws have been augmented to support physical tutorials [18]. In painting, a digital airbrush system aware of its location on the canvas provides feedback to the user [19]. Optical fibers in chef’s knives distinguish between fingers and ingredients [26].

Researchers have also explored cooperative forms of making that question the current delegative relationship between designers and fabrication machines [23, 2], and new input streams beyond CAD for defining geometries [23].

Many of the smart tools discussed above are manual tools that have been augmented with sensing, actuation, and computation. Our tool is most similar to Zoran’s FreeD and Rivers’ position correcting router. While those two tools operate primarily on 3- and 2-D stock material respectively, our tool is designed to operate on 1-D stock by creating new geometries at the edges and ends of lumber.

Rivers and Zoran sought to imbue novice users with the tacit skills required to operate manual tools through intelligence embedded into the tool itself; in contrast, we seek to develop new interactions that enable users to more directly express their design intent to CNC tools, such that these CNC tools become more like hand tools in nature. Hand tools are valued for the directness with which a user can act through the tool, and CNC tools are valued for their precision and repeatability. However, these two classes of tools are difficult to work with for distinct reasons – Zoran and Rivers addressed the level of manual skill required to proficiently use hand tools, and we address the difficulty of expressing design intent to a CNC tool. These dual approaches share the common goal of facilitating symbiotic collaborations between humans and the tools we use to create physical artifacts.

New Digital Fabrication Tools

The landscape of digital fabrication tools has rapidly expanded beyond the additive and subtractive fabrication of polymers.

New tools have explored digital fabrication of soft objects through felting [4] and layering [13], and glass objects through 3D printing [7]. Other work introduces new areas for digital fabrication, including fully 3D printed electromechanical assemblies [12], the combination of additive and subtractive

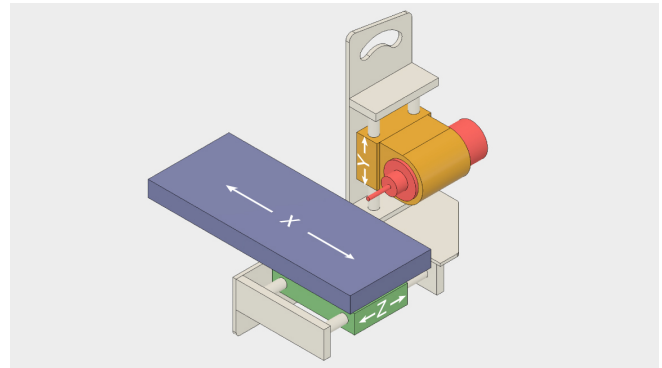

Figure 5. Y-axis (orange, 3.5 inch travel) carries the router (red); Z-axis (green, 2.5 inches travel) plunges in-line with the router spindle; X-axis (blue, 7 inches travel) is coupled to the Z axis.

fabrication for iterative design [20, 21], and portable fabrication machines [11, 15].

Researchers have also been interested in tools that can create objects beyond the scale of the digital fabrication machine. 3D printable connectors were combined with up-cycled plastic bottles [8]. Architectural scale objects were created by a foam depositing heterogeneous robot arm [6] and jammed wooden sticks [25]. Multiple efforts explore the transformation of a 2D fabricated geometry into larger 3D objects [1, 16].

Our project extends this vocabulary of context specific CNC tools into the domain of woodworking.

Machine Design

Most similar to our machine’s layout and capabilities is the Pantorouter designed by Matthias Wandel³. The Pantorouter uses templates and a large pantograph mechanism to cut the appropriate geometries; our tool uses Computer Numeric Control to replace the additional mass and templates. Horizontal spindles in general have been used in machine designs to maximize chip removal or make cuts with fully supported tools.

Our machine is the first personal CNC machine designed specifically for wooden joinery. This goal influenced many design decisions including the configuration of the spindle, the layout of the gantry, and many other features.

SYSTEM DETAILS

Mechanical Design

The machine tool used in our MatchSticks system is a 3-axis CNC milling machine (Figure 5). Unlike most CNC mills, our router is held horizontally. This configuration, combined with the ability to easily fixture parts in a variety of orientations, allows us to make cuts that would be extremely difficult due to undercuts, fixturing, and constrained machining volume.

The Y-axis (orange) carries the router up and down with a range of 3.5 inches (~90 mm) on linear round rails driven by a leadscrew. The Z-axis (green) has a plunge range of 2.5 inches (~60 mm); it similarly travels on linear round rails driven by a leadscrew. The X-axis (blue) can travel 7 inches (~180mm),

³<https://woodgears.ca/pantorouter/>

is coupled to the Z axis, and rides on V-groove tracks with rack and pinion drive. This configuration for the X-axis allows the length of the X-axis to be easily increased to machine continuous features along the edges of even longer boards.

The machine's kinematics are heavily over-constrained for maximum stiffness and minimum deflection under load. Components requiring high accuracy, such as the end blocks to support the round rails, are hand machined from precision ground aluminum stock. The machine's reinforcing structure, whose tolerances do not need to be as accurate, is constructed from waterjet 1/4 and 1/8 inch aluminum plate. CNC machined MDF, HDPE, Delrin, and plywood are also used throughout the machine for the X-axis deck, spindle mount, bushing blocks, and handle and fixturing mechanisms. A standard off the shelf trim router⁴ is used as the cutting tool.

Mechanical Design Feature Highlights

Size — While the bounding box of our machine is less than 1 cubic foot, the stock material that this machine can work with can be many times larger.

Portability — Our design intentionally tries to indicate affordances more akin to a hand power tool rather than a CNC machine. This is highlighted by the large wooden handle incorporated into the structure of the frame, allowing it to be easily moved throughout a workshop. The use of a battery powered trim router allows our device to function wirelessly.

Fixturing — The deck of our X-axis supports a variety of ways to fixture wood. Our design incorporates T-tracks for clamps and reference holes for dowel pins used for alignment. Figure 4 summarizes multiple ways in which parts can be fixtured.

Zeroing — A line laser mounted to the frame visually indicates the current location of the spindle along the X-axis. This allows for fast and accurate visual alignment for cuts (in our experience, easily within +/- 0.5mm). While the joints themselves need to be very precise, the location of the joint along the edge of a piece of wood need not be as accurate, or can be compensated for by tracking reference faces (Figure 3).

Why Create a Custom CNC Machine Tool?

Operating on the ends and edges of boards is possible to do using a traditional flatbed CNC machine, but would require significant modifications to that machine. We chose to design our own for the following reasons:

Max Part Size — A board mounted on edge into a traditional flatbed CNC can only be as long as the distance between the floor and the router. Depending on the gantry configuration, a hole will likely need to be cut into the bed of the CNC machine. By placing the axis of the spindle horizontally, our machine can operate on arbitrarily long pieces.

Gravity — If the bed of a traditional CNC router is now vertical to operate on the edges of the board, fixturing pieces of wood held vertically can be difficult and error prone. Gravity is not on your side — fixturing parts precisely is difficult when the part wants to fall as soon as you let it go. With a horizontal spindle, boards are allowed to lie flat.

⁴Makita RT0901C

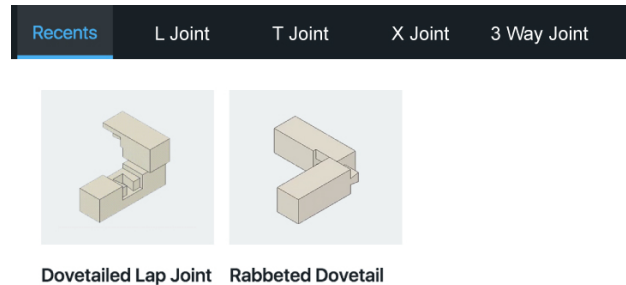

Figure 6. The web application's user interface for selecting the complementary cuts for recently downloaded joints.

Poor Impedance Matching Between Machine Size and Feature Size — Flatbed CNC machines are often large in order to maximize the size of planar stock material they can accommodate. However, joints themselves are small — our machine is designed to exploit this fact.

Unique Affordances — Most importantly, by designing our custom CNC machine, we have complete control over its aesthetics, affordances, and capabilities. It can be designed to be portable, extendable, modular, or even battery powered.

Electronics

When the device is powered through the wall, we use a 24V power supply to power the motors, regulated to 5V for the control electronics. In battery powered operation, we use a 3300mAh 4 cell LiPo battery and a similar battery powered trim router⁵. The gantry is driven by three stepper motors. An Arduino running Grbl, an open source motion control software for CNC machines,⁶ handles motor control. A Raspberry Pi 3 communicates with the Arduino, streaming G-code and reading the state of the machine. All major computation such as storing joint information, generating G-code, controlling the machine, etc., is handled through a web application rendered by the Raspberry Pi and displayed on a 7 inch touchscreen mounted to the machine's frame.

User Interface

Unlike hand tools that have no interactive interface, or digital fabrication tools that depend on external computers, MatchSticks is designed to afford direct, immediate, and creative workflows as directed by the user through handed interaction with the material and the machine.

The touch screen user interface (UI) serves to localize interaction with the tool. Both the design and fabrication of a part are directly at hand, rather than diffused to multiple workstations, software packages, or moments in time.

The UI was built using the Sinatra DSL⁷, which facilitates distributed services like downloading new joint types. The system is designed with modularity in mind – in future work, we envision many of these machines working together in a distributed manner within a workshop. The same UI can support machines with different routing characteristics and

⁵Makita XTR01z

⁶Grbl: <https://github.com/gnea/grbl/>

⁷Sinatra: <http://www.sinatrarb.com/>

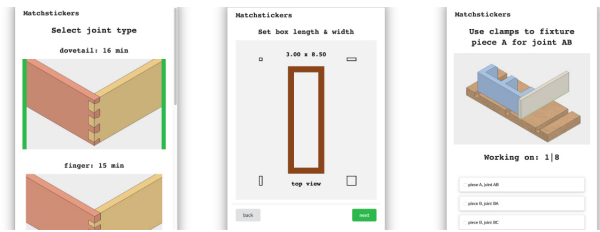

Figure 7. The web application's user interface for selecting the joint type and inputting the size of the stock.

limitations. Further, each machine has access to the global state of the project: which joints have been made, and which still need to be made. The UI can guide the user step-by-step through various joinery workflows.

The vector image of the contour and toolpath are rendered using Paper.js.⁸ To generate the toolpath, the outer contour of the cut is incrementally offset inwards using the Javascript Clipper⁹ library. These offset contours are discretized and used to generate the toolpath G-code. Once the user finalizes their design, the generated toolpath file is streamed to the Arduino over a local serial connection.

Joint Primitive Library

We categorize the joints our system can create based on where they occur on the pieces to be joined: end to end (L joint), end to middle (T joint), and middle to middle (X joint). Multi-way joints are categorized separately. In Figure 8, we show example joints in these four categories. We present these eight joints as examples; they are not an exhaustive list of the joints that can be created by our system.

The categories in this taxonomy address the high level design decision of "What are the ways I can put these two wooden pieces together in this position?" This question is encountered frequently when creating wooden structures. The taxonomy introduces some redundancy in the style of the joints between categories, for example, a lapped joint (Figure 8, column 4) can be easily modified to become an L or T joint; this redundancy allows joints to be found when asking the question above.

While our CNC machine cannot capture all of the joints that can be made by a skilled artisan with all their tools and skills, our machine is capable of creating many commonly used joints, and creates opportunities to fabricate joints which are substantially more difficult otherwise.

WORKFLOW

Open-Ended Design Workflow

Recalling the hypothetical described in the introduction, we concretize the example in the context of MatchSticks.

The user begins with a high level design sketch. Using the atomic operations described below, she cuts a first joint and its mate. After inspecting the result and evaluating how it fits

with her larger design vision, she iteratively cuts additional joints and assembles the final piece.

In this workflow, minimal guidance is given to the user beyond the available parametric joint library. The joints are arranged within the X, L, and T hierarchy for easy navigation when only the high level design intent is known. Other hierarchical groupings of joints that allow for rapid traversal of the design space can also be explored, such as grouping by the type object the user is trying to create.

This workflow is in some ways similar to the use of a miter saw, in which the user sets up a fixturing and chooses a machine setting, then performs an atomic operation on the material. With this machine, the user positions and clamps the wood in place, but rather than choose what miter angle to cut the workpiece at, the user chooses the type of joint that they would like to place on the piece of wood. The machine then cuts out that joint when it is commanded by the user. Like traditional woodworking tools, the design effort of creating the high level topology of the object lies solely with the user.

The user of this workflow should have some familiarity in designing objects, and the high level design can simply be sketched out by hand, or created using a lightweight CAD program. Because the complexity of the joinery has been abstracted into our system, we speculate that the inflection point for when a user would design by simply sketching out a model on paper versus using a CAD software will shift such that only very complex designs will need CAD modeling. Experienced users are also able to upload custom joints.

Cutting a Joint

Like all CNC machines, our tool can repeatably home into a known location. Therefore, the system is always aware of the height of the bed, as well as the location of the various holes for alignment pins. A zero plate is available for use when manual zeroing is required.

To cut a joint after it has been selected by the user:

1. The user inputs the dimensions of the piece of wood. The joint geometry is modified for this piece of wood.
2. Our system graphically indicates how the wood should be fixtured on the bed, so that the machine knows the piece's location.
3. The user confirms that they have fixtured the wood appropriately, and commands the system to make the cut.
4. The geometry is milled out.
5. The joint that will mate with the just-created joint is stored by the system for future operations.

Tutorials

The graphical user interface allows us to explore tutorials for woodworking projects. In addition to aiding the user through the fabrication of a single joint pair as described above, our system provides contextual information on how long the stock material should be, how and where to fixture the workpiece, zeroing the work if necessary, and in what order the cuts should be made.

⁸Paper.js, vector graphics scripting framework: <http://paperjs.org/>

⁹Clipper: <https://sourceforge.net/p/jsclipper/wiki/Home>



Figure 8. We categorize the joints our machine can create based on the orientation in which they come together. Top row shows assembled joints, bottom row shows disassembled joints. From left to right: dowel pin joint, framing joint, finger joint, angled mortise and tenon, pivoting lap joint, angled lap joint, three way interlocking tenon joint, and three way lapped joint. All example joints are created from poplar.



Figure 9. This poplar toolbox employs a variety of joints that would be difficult to create using current handheld and CNC tools.



Figure 10. A variety of specialized router tools exist in woodworking. This example was created with a tapered router bit. The joints are highlighted by the alternating use of Peruvian Walnut and Birdseye Maple. While the boards used to construct this box have not been planed flat, the joints fit snugly because the contact areas of the joint have been *locally planed* (Left, locally planed area outlined).

We have created one such tutorial for fabricating a parametric box whose joint types and geometry are customizable. This tutorial was generated by the authors, but in the future could be inferred from 3D models of objects. By simplifying one of the most difficult elements of woodworking, our system augments the existing design and making abilities of the user.

EXAMPLE FABRICATED DESIGNS

Using our system, we created four example objects: two toolboxes, one side table, and one woodworking bench. These objects each display key capabilities of our system.

Toolbox 1

The sides of this poplar¹⁰ toolbox (Figure 9) come together at half-blind dovetail joints, a technique that requires considerable tacit skill to produce using hand tools. With CNC routers that exist today, this joint is difficult to produce, and generally requires specialized fixtures.

With our system however, this toolbox can be easily fabricated due to the ease with which lumber can be fixtured in various orientations. In addition, our software system removes the need to design and CAM the joint itself, allowing the user to more quickly move from design intent to physical artifact.

Toolbox 2

In the design of Toolbox 2 (Figure 10), we demonstrate the ability of our system to machine hardwoods, use non-cylindrical router bits, work with non-rectilinear stock material, and create localized reference geometries. Many specialized router bits with irregular cut profiles are available for woodworking; for this toolbox, we used a flared router bit to produce the distinct sharp inside corners at the dovetails. Unlike dovetails cut using a dovetailing jig, we created dovetails with uneven spacing for a more interesting aesthetic. The handle is a maple dowel; the diameter at the ends has been reduced using a helical boring toolpath on our machine.

To create high quality joinery, stock material is typically jointed (made square) and planed (made parallel) before the joints themselves are cut. These operations are typically done with large machines that process the entire surface of the stock material. In contrast, the flexibility of our CNC machine allows us to *locally* surface the stock at the location of the joints such that the joint lines up perfectly, even if the underlying lumber has slight irregularities (Figure 10 left).

Finishing steps, such as inseting the base of the toolbox or shaping the vertical components of the handle, are not fabricated using our tool, but with hand and power tools that are better suited for these details. This process integrates our tool into the broader ecosystem of the woodshop.

¹⁰Poplar refers to the type of wood used. Poplar is a widely available, low/medium-density wood commonly used in furniture and cabinetry.



Figure 11. Three styles of joints (X, T, and L) are used in combination to create this table. All pieces used in this table are longer than any dimension of our CNC tool.



Figure 12. In traditional woodworking, a large flat piece of wood can be difficult to source or construct, requiring a variety of specialized tools. In this example, we use plywood for the tabletop and maple lumber for the components of the legs, demonstrating the complementary capabilities of traditional CNC routers and our tool.

Side Table

The side table (Figure 11) required all three types of joints classified in our taxonomy. The legs join to the bottom cross bracing with double tenons (T), and to the top cross bracing with dovetail joints (L). The cross braces use a simple lapped joint (X). All components of this table are longer than any dimension of our CNC tool. The tabletop itself is an example of a geometry not well suited for fabrication using 1D members as the stock material, and is made using a complementary process. In this example, it is fabricated from a transparent sheet to highlight the joints from which the structure is composed.

Mini Woodworking Bench

Our final example demonstrates a miniature Roubo¹¹ inspired workbench designed to raise workpieces above a standard worktable for a more comfortable working height (Figure 12). We use plywood for the tabletop, demonstrating the complementary capabilities of traditional CNC routers for 2D stock material, and our CNC router for 1D stock material. The legs supporting the top are machined by our system from 3x3 maple furniture squares.

¹¹A style of workbench named after André Jacob Roubo (1739-1791), a master cabinetmaker and author of a highly influential treatise on woodworking

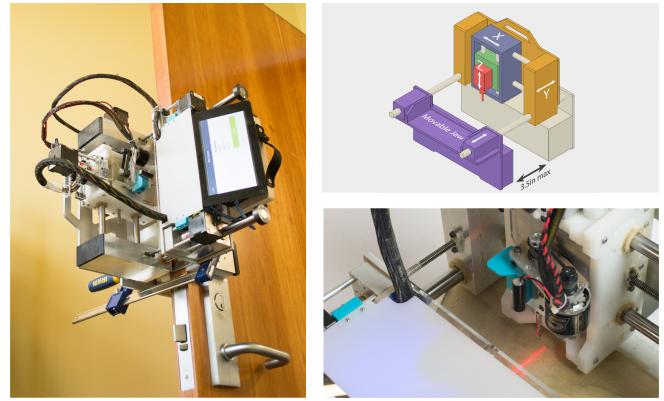

Figure 13. This variant of the MatchSticks device is designed to be clamped onto large pieces of wood that are difficult or impossible to move. Left, the device is set up for creating a mortise on a door for a deadbolt assembly in situ. Top right, diagram of kinematics, showing the movable jaw axis.

OTHER MACHINE CONFIGURATIONS

Building even larger structures may involve situations where moving the piece of wood is difficult or impossible either due to its size or its inclusion in an existing structure. In these scenarios, an alternate configuration of MatchSticks can be used (Figure 13), focused on mobility.

Rather than clamping workpieces into the CNC machine, the machine is designed to be clamped onto the workpiece. It is portable and battery powered to provide freedom of movement. In addition to the standard 3-axis milling head, there is an additional fourth axis integrated in-line with the Y-axis which allows various pieces of wood to be clamped between the jaws of the machine. The linear rails for the vise axis are shared by the actuated Y-axis of our machine, and the clamping force is provided by off-the-shelf clamps. As in the primary design, the motivation for this configuration is to access machining locations along the edges and ends of boards. While the kinematic configuration of this machine differs, there are many similarities in physical affordances, from the touchscreen that allows users to quickly access a library of joint designs, to the line laser and physical handle that allows the users to easily reposition the machine.

USER STUDY

We recruited 6 participants (4 male) to use MatchSticks in a 2 hour study in a local woodshop. All participants were registered users of the woodshop, with prior training on the basic tools and machines. All participants self-reported some hand tool experience, from intermediate to expert; digital fabrication experience ranged from none to expert.

During the study, users were introduced to MatchSticks, invited to fabricate a wooden box that they then took home, and interviewed about the experience. Four out of the six completed the entire user study and their box within the allotted 2 hours (Figure 14). Two completed an abbreviated, 1 hour study in which they cut joints but did not complete the box due to time constraints.

Participants followed the tutorial style described in *Workflow*, presented on the integrated touchscreen. Through the tutorial,



Figure 14. Four participants completed the box.

each individual participant chose the dimensions of their box and the type of joints, cut stock material on a saw, milled their joints on MatchSticks, and assembled the final box by hand. We synthesize qualitative findings to evaluate our design and to inform future interactive tools.

Capability and Accessibility

In prior projects, participants chose joining techniques based on speed, ease, or materials at hand. This tool opened up complex joinery as an option, challenging their perceptions of joinery as prohibitively difficult or intimidating. The woodworkers more experienced in joinery expressed renewed interest and confidence to attempt challenging projects:

P6 [The tool] would lead me to do fancier projects. I'd be less afraid.

P4 When I was making 30 drawer boxes I was like [expletive] no I'm not going to do dovetails...but if it was an option, and I could just machine these...that's exciting.

For some participants, this was their first experience with joinery. Not only did these novice users successfully complete the box project, but they now perceived joinery and CNC machining as techniques accessible to them.

P5 If I was to make a box with only hand tools, I wouldn't have made dovetails or interlocking parts. [MatchSticks] makes more difficult things easier for me.

P3 If I were to make a box, I wouldn't want screws going into sections like this, so having a library to select joints from and entering my dimensions would be really convenient.

P5 I feel like I can do so many more things, like it gives me so many more options. [I had thought] CNC is...for when you're older and know more things and understand all the coding and stuff. This is eye opening because I realized CNC machines can help me even if I don't understand all of that.

Quality was a key component in users' discussion of enjoyment and satisfaction with their woodworking projects. Both novice and expert users commented on the quality they achieved with MatchSticks:

P4 I'm extremely impressed; I know how hard it is to get those tolerances, it's extremely hard.

P3 I like it, the edges are really straight, and it feels really sturdy, and won't turn into a parallelogram. It was a really nice fit, and all the edges are flush.

Comparisons to Other Machines

After interacting with MatchSticks, participants characterized their experience in comparison to other woodworking tools they had used. They felt MatchSticks supported a more flexible, free-form, and natural workflow than a CNC machine while enabling greater capability than a traditional hand tool. Traditional CNC workflows are linear, slow, and inflexible, which participants found limiting.

P2 I have to finish all the design on my laptop, then go there and do the work, and then try to make all the joints, see if it works or not. And then I'm done. I can't modify anything.

P6 You have to have it perfect before you hit the play button.

But hand tool workflows are more flexible and interactive:

P1 Hand tools are inherently more improvisational than a machine.

P6 With handtools and even with [MatchSticks], you can be halfway through and fudge something and get it there.

After using MatchSticks, participants approached the CNC capabilities of the tool with an interactive mindset more akin to a hand tool. In particular, adjusting designs on the fly:

P2 [With MatchSticks,] you can design during the fabrication process. If you make [a mistake], you can still make it part of the design.

P6 It really is an in-between. It's quick like a hand tool...and it's empowering [like] the CNC.

Workflow and Viscosity

Participants noted fundamental differences between a workflow with MatchSticks, and a workflow with a traditional CNC tool. MatchSticks' more flexible approach to design and fabrication inspired new perspectives on the relationship between tool, material, and design, radically different from a traditional CNC's design-convert-wait workflow.

P6 [MatchSticks is a] really great conversational CNC type of device, where you have your drawings, you have your idea, you walk up to it and it kind of does a few calculations for you...I would not be able to walk up to a Tormach [CNC] and be like, 'Hey cut a joint for me.' It would be like, 'Give me some G-code, baby. I can't do nothing until you've done all the CADing and CAMing.'

The material has a voice in this process as well:

P6 You know what the biggest thing is probably, the use of scrap material in your project. Because when you're doing something with scrap...you end up changing things here and there as you move through it. So hand tools and maybe [MatchSticks] a little bit as well, you're working with what you have as you move along.

The parametric library frees regular interaction with the tool from a long digital design process:

P3 Doing my own CAD would be for my special use, if I had a special geometry and I had to design my own joint...but a library would cover what most people would want to build.

Design of the Machine

The affordances of the machine inspired new ideas for use cases, and increased comfort with the machine. MatchSticks can handle components far beyond the scale of the machine;

one participant suggested its use in timberframing (the construction of buildings using wooden beams and joinery):

P4 [the cut] would at the most be an 8 inch long by 2 inch wide...Those machines are huge that do that¹². So the idea of bringing the machine to the stock and having the precision of a CNC is really exciting.

Woodshops are inherently dangerous places. Some participants had avoided attempting dovetails or similar detailed work in the past because of how close their fingers would end up to moving blades. Users felt comfortable with MatchSticks, even in such a short time-frame, either commenting directly on its safety, or considering it equivalent to other tools.

P2 It's so compact, it doesn't look dangerous. Some wood tools look kind of scary. It feels way more safe. If you see a huge bulky machine, even if it's doing a really simple thing, they kind of frighten the user.

Satisfaction, Agency, and Craft

Finally, some participants reflected on the intangible aspects of working with wood, and the role of MatchSticks. One theme was direct interaction with the material:

P2 It's different from calibrating a 3D printer. It feels different, I'm actively working with the material...You know how a miter saw is like a hand tool, but still 90 percent is clamping and making the dimension and then cutting it: even if the machine is doing all the hard work, I think I'm doing most of the work.

A second theme was in the embodiment of craft. MatchSticks respects the knowledge and values of woodworking. The results maintain the aesthetics of traditional joinery, and the tool does not impart its own aesthetic onto the material.

P4 The sensations and the muscle memory involved with using traditional tools is very satisfying...There's a soulfulness that's missing in digital fabrication... the nice thing [about this machine] is that the joints are pretty pleasing... I think that just doing that adds a level of satisfaction about the craft that gets really lost with those extra holes [in dogbones].

Limitations

While many users felt empowered by their ability to create intricate joinery, some users with less or no prior digital fabrication experience felt detached from the actual making process:

P1 The design is in my control, but the process is not. Which is good or bad, depending on who can do the process better - in this case it's definitely the machine. I do feel a little out of control of the fabrication process.

P5 When using a computer, it's convenient, but I don't understand what it's doing, I just know that if I type something in I know what's going to come out. With hand tools, I understand exactly what's going on.

DISCUSSION AND FUTURE WORK

This tool is by no means an attempt to supplant traditional woodworking craftsmanship, or to replace other fabrication methods that work with wood. Rather, we are introducing a complementary process within the ecosystem of tools and techniques used for woodworking that is tailored for one of the

most common operations one would do on wood — creating joinery. By constraining a CNC machine to a very specific domain, and coupling it with a similarly focused software system, we have developed a workflow that can very quickly translate design intent to fabricated geometry. Reflecting on our fabrication of the example artifacts, this tool has greatly extended our own woodworking abilities. From the perspective of manual skill, this tool allows us to apply the accuracy and repeatability of Computer Numeric Control to fabricate geometries traditionally outside the scope of digital fabrication. Though we had to design many of these joints in order to populate the joint libraries, our user studies validated how a existing joint library can be used to dramatically reduce the viscosity of the design and fabrication of joinery.

The user studies also revealed a range of ways in which users imagine integrating a tool like MatchSticks into their workflows. The ways in which MatchSticks brings hand tool affordances to CNC capabilities encourages more interactive behaviors with the CNC tool, and more accessibility to joinery. Certain aspects of its CNC nature were off-putting: exploring the roots of these reactions and how to address the perceptions of lack of control and understanding may be a fruitful path for future work in rethinking the role of CNC tools. In future work, we would also like to investigate how expert users within the domains of digital fabrication and/or traditional woodworking incorporate this tool within their practice.

In future work, we plan to build out additional MatchSticks devices to explore the networked ecosystem of smart tools that our system enables. Methods for parallelizing fabrication, optimal planning, and collaborative workflows will be investigated. Imagine working with your friend to co-design and co-fabricate a chair, using a networked system of tools aware of the entire project state.

CONCLUSION

In this paper, we introduced MatchSticks, a digital fabrication system for joinery. Our tool introduces complementary capabilities to the domain of digital and hand tools used in woodworking while further exploring the area of interactive smart tools. We introduced novel hardware that is capable of expressing a large vocabulary of joints as well as software for design and fabrication that is similarly tuned to the domain of joinery. Our system enables the fabrication of geometries and assemblies that are (1) difficult to create using other tools, (2) larger than the tool itself, and (3) parallelizable in production. By eliminating the need to interact with a separate computer for the design of these joints, we explore how users can much more easily express their design intent directly to the CNC fabrication tool. This directness both empowers novices to incorporate joinery into their practice, while providing experts with an adaptive palette of joinery designs. We validate capabilities of our tool through the production of example artifacts, and a user study of a tutorial workflow.

ACKNOWLEDGEMENTS

We thank Molly Nicholas for her thoughtful edits, Eric Liang for developing early prototypes of the web application, and the anonymous reviewers for their valuable feedback.

¹²<https://www.hundegger.de>

REFERENCES

1. Harshit Agrawal, Udayan Umaphathi, Robert Kovacs, Johannes Frohnhofen, Hsiang-Ting Chen, Stefanie Mueller, and Patrick Baudisch. 2015. Prototyper: Physically Sketching Room-Sized Objects at Actual Scale. In *Proceedings of the 28th Annual ACM Symposium on User Interface Software & Technology (UIST '15)*. ACM, New York, NY, USA, 427–436. DOI: <http://dx.doi.org/10.1145/2807442.2807505>
2. Laura Devendorf and Kimiko Ryokai. 2014. Being the Machine: Exploring New Modes of Making. In *Proceedings of the 2014 Companion Publication on Designing Interactive Systems (DIS Companion '14)*. ACM, New York, NY, USA, 33–36. DOI: <http://dx.doi.org/10.1145/2598784.2602775>
3. Chi-Wing Fu, Peng Song, Xiaoqi Yan, Lee Wei Yang, Pradeep Kumar Jayaraman, and Daniel Cohen-Or. 2015. Computational Interlocking Furniture Assembly. *ACM Trans. Graph.* 34, 4 (July 2015), 91:1–91:11. DOI: <http://dx.doi.org/10.1145/2766892>
4. Scott E. Hudson. 2014. Printing Teddy Bears: A Technique for 3D Printing of Soft Interactive Objects. In *Proceedings of the SIGCHI Conference on Human Factors in Computing Systems (CHI '14)*. ACM, New York, NY, USA, 459–468. DOI: <http://dx.doi.org/10.1145/2556288.2557338>
5. Michael D. Jones, Kevin Seppi, and Dan R. Olsen. 2016. What You Sculpt is What You Get: Modeling Physical Interactive Devices with Clay and 3D Printed Widgets. In *Proceedings of the 2016 CHI Conference on Human Factors in Computing Systems (CHI '16)*. ACM, New York, NY, USA, 876–886. DOI: <http://dx.doi.org/10.1145/2858036.2858493>
6. Steven J. Keating, Julian C. Leland, Levi Cai, and Neri Oxman. 2017. Toward site-specific and self-sufficient robotic fabrication on architectural scales. *Science Robotics* 2, 5 (April 2017), eaam8986. DOI: <http://dx.doi.org/10.1126/scirobotics.aam8986>
7. John Klein, Michael Stern, Giorgia Franchin, Markus Kayser, Chikara Inamura, Shreya Dave, James C. Weaver, Peter Houk, Paolo Colombo, Maria Yang, and Neri Oxman. 2015. Additive Manufacturing of Optically Transparent Glass. *3D Printing and Additive Manufacturing* 2, 3 (Aug. 2015), 92–105. DOI: <http://dx.doi.org/10.1089/3dp.2015.0021>
8. Robert Kovacs, Anna Seufert, Ludwig Wall, Hsiang-Ting Chen, Florian Meinel, Willi Müller, Sijing You, Maximilian Brehm, Jonathan Striebel, Yannis Kommana, Alexander Popiak, Thomas Bläsius, and Patrick Baudisch. 2017. TrussFab: Fabricating Sturdy Large-Scale Structures on Desktop 3D Printers. In *Proceedings of the 2017 CHI Conference on Human Factors in Computing Systems (CHI '17)*. ACM, New York, NY, USA, 2606–2616. DOI: <http://dx.doi.org/10.1145/3025453.3026016>
9. Yuki Koyama, Shinjiro Sueda, Emma Steinhardt, Takeo Igarashi, Ariel Shamir, and Wojciech Matusik. 2015. AutoConnect: Computational Design of 3D-printable Connectors. *ACM Trans. Graph.* 34, 6 (Oct. 2015), 231:1–231:11. DOI: <http://dx.doi.org/10.1145/2816795.2818060>
10. Manfred Lau, Akira Ohgawara, Jun Mitani, and Takeo Igarashi. 2011. Converting 3D Furniture Models to Fabricatable Parts and Connectors. In *ACM SIGGRAPH 2011 Papers (SIGGRAPH '11)*. ACM, New York, NY, USA, 85:1–85:6. DOI: <http://dx.doi.org/10.1145/1964921.1964980>
11. Nadya Peek and Ilan Moyer. 2017. Popfab: A Case for Portable Digital Fabrication. In *Proceedings of the Eleventh International Conference on Tangible, Embedded, and Embodied Interaction (TEI '17)*. ACM, New York, NY, USA, 325–329. DOI: <http://dx.doi.org/10.1145/3024969.3025009>
12. Huaishu Peng, François Guimbretière, James McCann, and Scott Hudson. 2016. A 3D Printer for Interactive Electromagnetic Devices. In *Proceedings of the 29th Annual Symposium on User Interface Software and Technology (UIST '16)*. ACM, New York, NY, USA, 553–562. DOI: <http://dx.doi.org/10.1145/2984511.2984523>
13. Huaishu Peng, Jennifer Mankoff, Scott E. Hudson, and James McCann. 2015. A Layered Fabric 3D Printer for Soft Interactive Objects. In *Proceedings of the 33rd Annual ACM Conference on Human Factors in Computing Systems (CHI '15)*. ACM, New York, NY, USA, 1789–1798. DOI: <http://dx.doi.org/10.1145/2702123.2702327>
14. Alec Rivers, Ilan E. Moyer, and Frédo Durand. 2012. Position-correcting Tools for 2D Digital Fabrication. *ACM Trans. Graph.* 31, 4 (July 2012), 88:1–88:7. DOI: <http://dx.doi.org/10.1145/2185520.2185584>
15. Thijs Roumen, Bastian Kruck, Tobias Dürschmid, Tobias Nack, and Patrick Baudisch. 2016. Mobile Fabrication. In *Proceedings of the 29th Annual Symposium on User Interface Software and Technology (UIST '16)*. ACM, New York, NY, USA, 3–14. DOI: <http://dx.doi.org/10.1145/2984511.2984586>
16. Harpreet Sareen, Udayan Umaphathi, Patrick Shin, Yasuaki Kakehi, Jifei Ou, Hiroshi Ishii, and Pattie Maes. 2017. Printflatables: Printing Human-Scale, Functional and Dynamic Inflatable Objects. In *Proceedings of the 2017 CHI Conference on Human Factors in Computing Systems (CHI '17)*. ACM, New York, NY, USA, 3669–3680. DOI: <http://dx.doi.org/10.1145/3025453.3025898>
17. Valkyrie Savage, Sean Follmer, Jingyi Li, and Björn Hartmann. 2015. Makers' Marks: Physical Markup for Designing and Fabricating Functional Objects. In *Proceedings of the 28th Annual ACM Symposium on User Interface Software & Technology (UIST '15)*. ACM, New York, NY, USA, 103–108. DOI: <http://dx.doi.org/10.1145/2807442.2807508>

18. Eldon Schoop, Michelle Nguyen, Daniel Lim, Valkyrie Savage, Sean Follmer, and Björn Hartmann. 2016. Drill Sergeant: Supporting Physical Construction Projects Through an Ecosystem of Augmented Tools. In *Proceedings of the 2016 CHI Conference Extended Abstracts on Human Factors in Computing Systems (CHI EA '16)*. ACM, New York, NY, USA, 1607–1614. DOI: <http://dx.doi.org/10.1145/2851581.2892429>
19. Roy Shilkrot, Pattie Maes, Joseph A. Paradiso, and Amit Zoran. 2015. Augmented Airbrush for Computer Aided Painting (CAP). *ACM Trans. Graph.* 34, 2 (March 2015), 19:1–19:11. DOI: <http://dx.doi.org/10.1145/2699649>
20. Alexander Teibrich, Stefanie Mueller, François Guimbretière, Robert Kovacs, Stefan Neubert, and Patrick Baudisch. 2015. Patching Physical Objects. In *Proceedings of the 28th Annual ACM Symposium on User Interface Software & Technology (UIST '15)*. ACM, New York, NY, USA, 83–91. DOI: <http://dx.doi.org/10.1145/2807442.2807467>
21. Christian Weichel, John Hardy, Jason Alexander, and Hans Gellersen. 2015. ReForm: Integrating Physical and Digital Design Through Bidirectional Fabrication. In *Proceedings of the 28th Annual ACM Symposium on User Interface Software & Technology (UIST '15)*. ACM, New York, NY, USA, 93–102. DOI: <http://dx.doi.org/10.1145/2807442.2807451>
22. Christian Weichel, Manfred Lau, David Kim, Nicolas Villar, and Hans W. Gellersen. 2014. MixFab: A Mixed-reality Environment for Personal Fabrication. In *Proceedings of the SIGCHI Conference on Human Factors in Computing Systems (CHI '14)*. ACM, New York, NY, USA, 3855–3864. DOI: <http://dx.doi.org/10.1145/2556288.2557090>
23. Karl D.D. Willis, Cheng Xu, Kuan-Ju Wu, Golan Levin, and Mark D. Gross. 2011. Interactive Fabrication: New Interfaces for Digital Fabrication. In *Proceedings of the Fifth International Conference on Tangible, Embedded, and Embodied Interaction (TEI '11)*. ACM, New York, NY, USA, 69–72. DOI: <http://dx.doi.org/10.1145/1935701.1935716>
24. Jiaxian Yao, Danny M. Kaufman, Yotam Gingold, and Maneesh Agrawala. 2017. Interactive Design and Stability Analysis of Decorative Joinery for Furniture. *ACM Trans. Graph.* 36, 2 (March 2017), 20:1–20:16. DOI: <http://dx.doi.org/10.1145/3054740>
25. Hironori Yoshida, Takeo Igarashi, Yusuke Obuchi, Yosuke Takami, Jun Sato, Mika Araki, Masaaki Miki, Kosuke Nagata, Kazuhide Sakai, and Syunsuke Igarashi. 2015. Architecture-scale Human-assisted Additive Manufacturing. *ACM Trans. Graph.* 34, 4 (July 2015), 88:1–88:8. DOI: <http://dx.doi.org/10.1145/2766951>
26. Amit Zoran, Nan-Wei Gong, Roy Shilkrot, Shuo Yan, and Pattie Maes. 2015. Cutting Edge Vision: Metal Embedded Optics for Smart Knives. In *Proceedings of the 33rd Annual ACM Conference Extended Abstracts on Human Factors in Computing Systems (CHI EA '15)*. ACM, New York, NY, USA, 185–185. DOI: <http://dx.doi.org/10.1145/2702613.2732495>
27. A. Zoran, R. Shilkrot, P. Goyal, P. Maes, and J. A. Paradiso. 2014a. The Wise Chisel: The Rise of the Smart Handheld Tool. *IEEE Pervasive Computing* 13, 3 (July 2014), 48–57. DOI: <http://dx.doi.org/10.1109/MPRV.2014.59>
28. Amit Zoran, Roy Shilkrot, Suranga Nanyakkara, and Joseph Paradiso. 2014b. The Hybrid Artisans: A Case Study in Smart Tools. *ACM Trans. Comput.-Hum. Interact.* 21, 3 (June 2014), 15:1–15:29. DOI: <http://dx.doi.org/10.1145/2617570>